



INSTALLATION, OPERATION & MAINTAINANCE INSTRUCTIONS FOR TYPES HEAT TREATMENT SERIES SERIAL No F

THIS MANUAL IS FOR THE GUIDANCE OF OPERATORS FOR THE ABOVE
VECSTAR EQUIPMENT AND SHOULD BE READ AND UNDERSTOOD
BEFORE INSTALLATION AND OPERATION

CONTENTS

SECTION

- 1.0 SYMBOLS AND WARNING LABELS
- 2.0 MANUAL HANDLING & UNPACKING
- 3.0 INSTALLATION & SAFETY
- 4.0 OPERATION
- 5.0 MAINTAINANCE
- 6.0 SPARES & REPAIRS
- 7.0 FAULT ANALYSIS
- 8.0 CIRCUIT DIAGRAMS
- 9.0 SPECIFICATIONS
- 10.0 CONTACT DETAILS

VECSTAR LTD



1.0 SYMBOLS & WARNINGS

1.1 WARNING LABELS



Danger of electric shock read any warnings printed by this symbol.



Danger hot surface read any warnings printed by this symbol. Warning all surfaces of a furnace may be hot.



Earth bonding point for electrical safety.

1.2 LIGHTS & SWITCHES



Green mains on light illuminates when the supply is connected to the furnace.

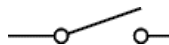

Green instrument switch illuminates when turned on.



Heat on light illuminates or flashes when power is applied to the element.

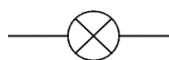

Red over temperature light illuminates if the furnace trips out in the event of an over temperature condition.

2.0 MANUAL HANDLING & UNPACKING

2.1 MANUAL HANDLING

Caution this equipment is heavy and should only be lifted from the base with a person on each corner. Never lift it by the door. Care should be taken not to trap fingers under the feet.

2.2 UNPACKING

Visually check for any damage to the shipping container.

Visually check for any damage to the equipment.

Open the furnace door and remove any packaging from the furnace chamber.

It is recommended to vacuum the furnace chamber to remove any insulation dust due to shipment.

Retain the original packaging if re-shipment is foreseen

Or required.

3.0 INSTALLATION & SAFETY

3.1 SITE SELECTION

The furnace should be placed on a heat resistant surface in a well ventilated room. Do not mount the furnace on an inflammable surface.

There must be at least 6 inches of space around the furnace to allow adequate ventilation.

Ensure the furnace is placed in a way it can easily be turned off or disconnected from the electrical supply.

If the furnace is to be used to heat materials that give off fumes it is recommended to have an extraction hood above the furnace.

3.2 ELECTRICAL CONNECTION

The image shows a metal nameplate for a Vecstar furnace. On the left, there is a logo for Vecstar Ltd with the website www.vecstar.co.uk and the location Chesterfield U.K. Below the logo is a CE mark and the telephone number 01246 260094. To the right of the logo, there are labels for SER. No., MODEL., VOLTS., AMPS., WATTS., and MAX TEMP. Each label is followed by a blank space for a sticker or handwritten information. The VOLTS. label has a small box with '50/60' and a phase symbol 'S'. The AMPS. label has a box with a slash and a circle symbol 'Ø'. The MAX TEMP. label has a box with 'T/C'.

SER. No.	[]
MODEL.	[]
VOLTS.	[] 50/60 S
AMPS.	[] / Ø [] Ø
WATTS.	[]
MAX TEMP.	[] T/C

Connection To Mains Supply

Furnace Voltage is - - - Volts, - - - Phase.

Connect to a - - - amp supply using suitable cable.

Connection by a qualified electrician is recommended.

All furnaces covered by this manual are either single phase live, neutral & earth non reversible or three phase live neutral & earth. Before connecting check the furnace specification plate on the back panel of the furnace. Make sure the supply voltage and capacity matches the voltage and amperage on the specification plate.

All incoming electrical supplies must be fused correctly.

If a cable is fitted either wire straight to a fused isolator or fit a fused line plug.

Please Note: The supply cable connections are:

Live = Number 1, Neutral = Number 2, Earth = green/yellow

Connection by line plug this should be within easy reach of the operator for removal.

Connection by isolating switch should disconnect both live and neutral conductors and be in easy reach of the operator to disconnect.

The supply must be earthed for safety reasons.

If in doubt please contact Vecstar.

Servicing should only be carried out by qualified personnel.

3.3 SAFETY

Your Vecstar furnace has been designed with function, reliability and safety in mind. It is the user's responsibility to install it in conformance with local electrical codes.

For user safety we strongly recommend the use of protective clothing including face shield and gloves when inserting or removing objects from this furnace. It is advisable to have a heat resistant surface available ready to receive hot objects.

To avoid electrical shock, this furnace must:

- 1. Use a properly grounded electrical outlet of correct voltage and current handling capacity.**
- 2. Be disconnected from the power supply prior to maintenance and servicing.**
- 3. Have the door switch operating properly.**

To avoid burns, this furnace must:

- 1. Not to be touched on the exterior or interior surfaces during use or for a period of time after use.**

To avoid personal injury :

- 1. Do not use in the presence of flammable or combustible materials; fire or explosion may result. This device contains component's, that may ignite such material.**
- 2. Refer servicing to qualified personnel.**

4.0 OPERATION

4.1 INTENDED USE

The furnace is a general purpose laboratory and heat treating of material and should not be used for anything else other than its intended purpose.

4.2 The instructions for operating the controller, over temperature controller if fitted and timer if fitted are given in separate booklets.

4.3 PRINCIPLES OF OPERATION

The furnace is heated by a wire element suspended on ceramic tubes and insulated with a mixture of ceramic fibre and board. The temperature is controlled by a pid controller using a thermocouple to control the temperature. A door safety switch is fitted to remove the power to the heating element when the door is opened. Mains on the green light will illuminate when power is applied to the furnace. Instruments on / off switch and the controller will illuminate when turned to the on position. Heater on The amber light will illuminate whenever the elements are drawing power. Over temperature is controlled by means of a thermal fuse which trips at a set temperature. The door safety switch disconnects the power from the elements when the door is opened. The amber heater on light will go out while the door is open if this does not happen consult the trouble shooting guide.

4.4 FURNACE LOADING

For best results, use only centre two-thirds of the furnace chamber.

CAUTION

Do not overload your furnace chamber. If the load is to be heated uniformly it should not occupy more than two-thirds of the furnace chamber.

If you are heating a number of small parts, spread them throughout the centre two-thirds of the furnace chamber.

Use insulated tongs and mittens when loading and unloading the oven.

Always wear safety glasses.

Keep objects away from the thermocouple.

4.5 USE OF PROBES

Any kind of metal probes that are inserted in to the furnace chamber while the furnace is switched on must be earthed. Unearthed probes can cause serious electric shock.

4.6 GAS ATMOSPHERES

When a optional gas inlet is fitted only inert gases must be introduced into the chamber.

4.7 ELECTRONIC OVER TEMPERATURE

When a optional digital over temperature is fitted this must be set to the correct temperature before starting a heat cycle.

5.0 MAINTAINANCE

5.1 CLEANING

Soot and scale may build up inside the chamber. This must be removed at regular intervals as they may affect the furnace efficiency.

5.2 ELECTRICAL CONNECTIONS

All electrical checks should be carried out by qualified personnel.

Electrical connections should be checked periodically to make sure all connection are tight.

The door safety switch should be checked weekly to make sure it is in good working order and it cuts the power to the elements when the door is opened.

6.0 SPARES AND REPAIRS

Vecstar have a team of qualified engineers that can carry out repairs either at the customers premises or the furnace can be returned to our premises for repair. A telephone call in most cases will identify the fault and a spare part can be despatched.

All furnaces have their own records so please quote the serial number, model type and voltage that can be found on the rating plate on the back of the furnace.

Vecstar can supply a recommended kit of spares or individual spares as required please quote serial number, model type and voltage that can be found on the rating plate on the back of the furnace.

7.0 FAULT ANALYSIS

<u>FAULT</u>	<u>Possible causes to check</u>	<u>Corrective action</u>
<p><u>The furnace does not heat up</u></p> <p>The heat on light is on</p> <p>The heat on light is off</p> <p><u>Furnace overheats</u></p> <p>The heat on light stays on all the time</p>	<p>Heating element</p> <p>Thermocouple</p> <p>SSR switch</p> <p>Door switch</p> <p>Safety contactor</p> <p>Controller</p> <p>Thermal fuse</p> <p>SSR switch</p> <p>Over temp alarm controller</p> <p>Safety relay</p> <p>Wrong thermocouple</p>	<p>Replace element and any contaminated material</p> <p>Replace any part found to be faulty</p> <p>Replace any part found to be faulty</p>

8.0 STANDARD WIRING DIAGRAM

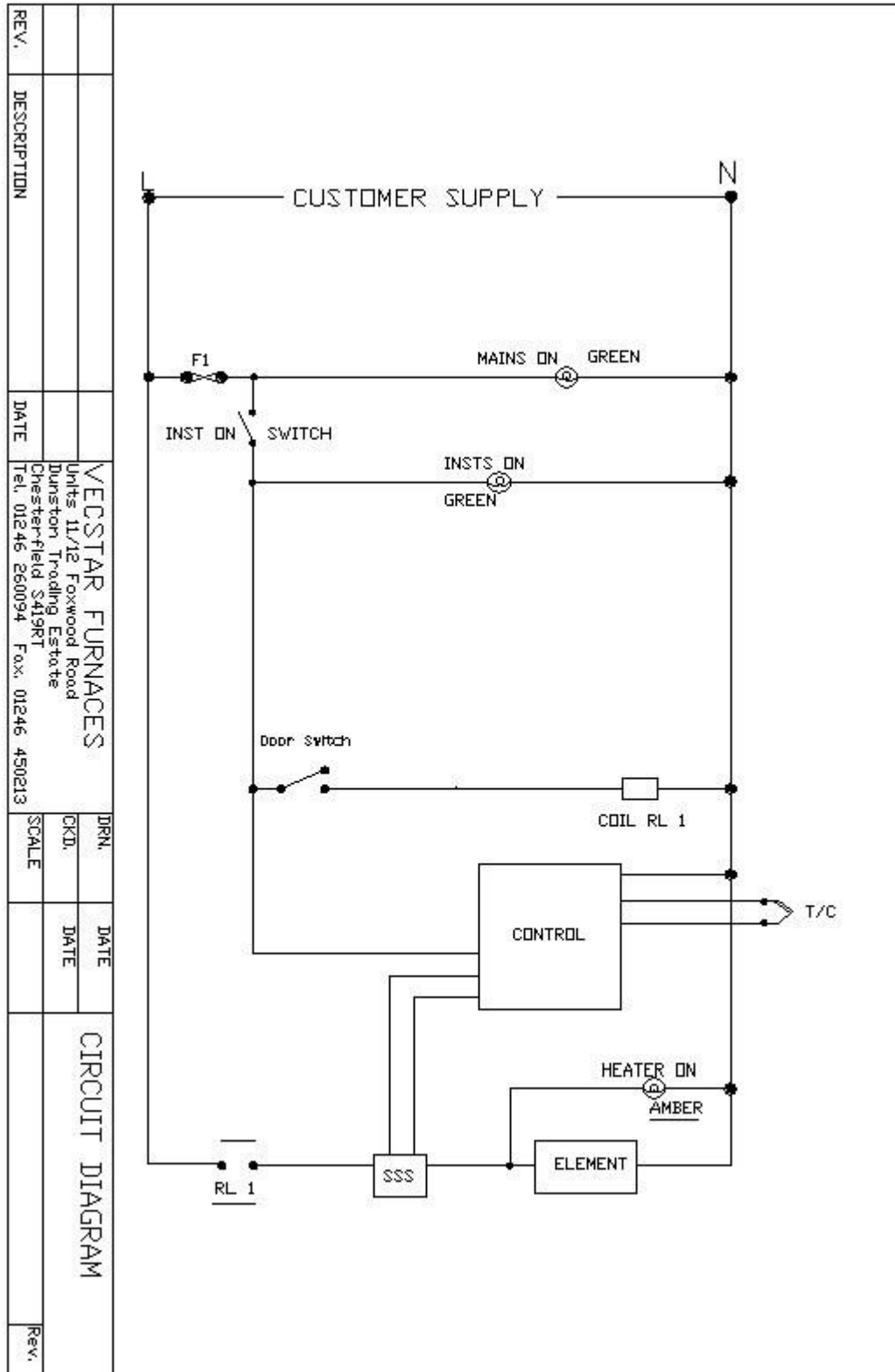

8.1 OVERTEMPERATURE WIRING DIAGRAM

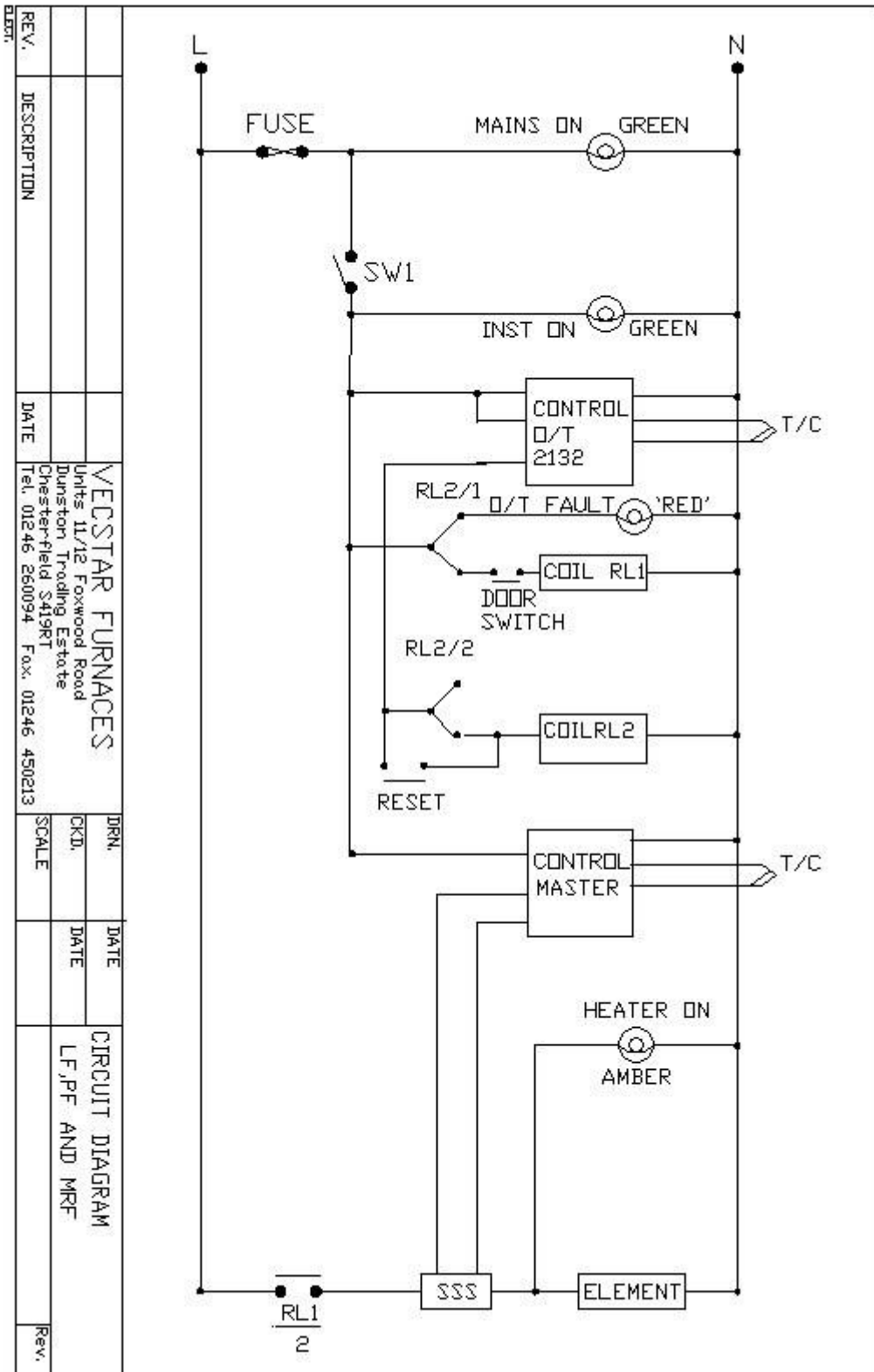

10.0 CONTACT DETAILS

The products covered in this manual are only a small part of our extensive range of our ovens, tube furnaces, chamber furnaces and hot plates for laboratory and industrial use. Please visit our web site at www.vecstar.com or contact us at the address below for more information.

UK Contact



Vecstar Limited
Units 11 & 12 Foxwood Road
Dunston Trading Estate
Chesterfield S41 9RF
Tel: 01246 260094
Fax: 01246 450213
Email: uksales@vecstar.com

USA Contact



Vecstar Limited
Tel: 1-877-842-4652
Email: sales@vecstar.com